

# Thermal Tactile Perception: Device, Technology, and Experiments

Junjie Bai, School of Electrical Engineering, Chongqing University of Science and Technology, Chongqing, China

Jun Peng, School of Intelligent Technology and Engineering, Chongqing University of Science and Technology, Chongqing, China

 <https://orcid.org/0000-0001-6800-0064>

De Dong Tang, School of Electrical Engineering, Chongqing University of Science and Technology, Chongqing, China

Zuojin Li, School of Electrical Engineering, Chongqing University of Science and Technology, Chongqing, China

Kan Luo, School of Information Science and Engineering, Fujian University of Technology, Fuzhou, China

Jianxin Li, School of Information Science and Engineering, Fujian University of Technology, Fuzhou, China

Xue Zhang, School of Electrical Engineering, Chongqing University of Science and Technology, Chongqing, China

## ABSTRACT

Using thermal tactile sensing mechanism based on semi-infinite body model, and combining with the advantages of maximum proportional controller, fuzzy and PID controller, a thermal tactile perception and reproduction experiment device (TTPRED) was designed based on the composite control strategy of threshold switching. The finger difference threshold measurement experiment of thermal tactile was carried out, and the finger thermal tactile difference threshold was measured. The relationship between thermal tactile sensation and emotion based on temperature cues has been explored. The experiment results show that the temperature control range of TTPRED is from  $-10^{\circ}\text{C}$  to  $130^{\circ}\text{C}$ , the temperature resolution and precision are  $0.01^{\circ}\text{C}$  and  $\pm 0.1^{\circ}\text{C}$  respectively, the maximum heating or cooling rate is greater than  $12^{\circ}\text{C}$ , and the TTPRED can realize the temperature output of the specific waveform quickly and accurately. The experiment results of psychophysical experiment will provide the experimental foundations and technical support for the further study of thermal tactile perception and reproduction.

## KEYWORDS

Composite Control, Intelligent Algorithm, Intelligent Perception, Perception and Reproduction Experiment Device, Thermal Tactile

## 1. INTRODUCTION

Touch is the fifth sense, the most complex and important sense of human beings. Nerve cells distributed on the skin of the whole body receive the sensation of temperature, vibration, humidity, texture, shape, pressure and other aspects from the outside world, so as to perceive the external environment (Maclean, & Hayward, 2008).

DOI: 10.4018/IJCINI.20211001.0a22

This article published as an Open Access article distributed under the terms of the Creative Commons Attribution License (<http://creativecommons.org/licenses/by/4.0/>) which permits unrestricted use, distribution, and production in any medium, provided the author of the original work and original publication source are properly credited.

Psychophysicists believe that tactile sense can effectively transmit information, perceive and reproduce common artistic behaviors, which is no less than auditory sense and visual sense, and has irreplaceable advantages in some aspects, but this ability has been ignored for a long time (Lederman, & JONES, 2011; Shockley, Carello, & Turvey, 2004).

Since 2000, as the means of acquiring data has become more complex and the amount of data has increased, touch has been needed to aid visual and auditory sense. In addition, strong sense of immersion and human-computer interaction need to be embedded into the virtual environment. Tactile perception and reproduction technologies have been rapidly developed (Choi, & Kuchenbecker, 2013; Karam, Russo, & Fels, 2009; Marshall, 2008; Giordano, & Wanderley, 2013; Yao, Shi, Chi, & Ji, 2010; Hwang, Lee, & Choi, 2013; Yu, Song, Chen, & Zhang, 2017). At present, domestic and foreign scholars have carried out many fruitful works on the research of force tactile perception and reproduction devices (Giordano, & Wanderley, 2013; Yao, Shi, Chi, & Ji, 2010; Hwang, Lee, & Choi, 2013; Yu, Song, Chen, & Zhang, 2017). Many force tactile reproducing devices also combine thermal touch, force touch and muscle motion perception, showing a kind of compound sense reproducing device. Thermal tactile perception and reproduction technology is relatively rare, and related researches have been carried out on thermal tactile perception mechanism, thermal tactile reproducing device and material identification (Yang, Jones, & Kwon, 2008; Wu, Zhou, Li, Wu, & Chen, 2010; Zhou, Li, & Chen, 2010; Bai, Li, Chen, Wu, & Cai, 2011; Hirai, & Miki, 2019; Chen, Wang, & Wang, 2016). However, the performance of the thermal tactile perception and reproduction experimental device needs to be further improved and functionally diversified, and more thermal tactile psychophysical experiments should be carried out according to actual application requirements.

In this paper, a composite device of thermal tactile perception and reappearance was designed by using composite control technology, and psychophysical experiments were carried out on the thermal tactile perception.

## 2. FINGER THERMAL TACTILE PERCEPTION MECHANISM

The mechanism of thermal tactile perception is the research basis for the development of thermal tactile perception and reproduction. The tactile perception and reproduction device must be designed according to the characteristics of human receptors.

If the contact time of two objects is short enough, it is effective to use a semi-infinite body model to solve the heat transfer problem between them. The heat transfer theories of finger-object contact has been explored based on the model, and analyzed the mechanism of thermal tactile perception (Jones, & Berris, 2003; Yang, Kwon, & Jones, 2009; HO, & Jones, 2008). As shown in Figure 1 (Bai, Li, Chen, Wu, & Cai, 2011), based on the semi-infinite body model, the heat transfer control equations between the finger and the object are as shown in equations (1) and (2) in a short time when the finger and the object are in contact.

$$\frac{\partial^2 T_s}{\partial x_1^2} = \frac{1}{\alpha_s} \frac{\partial T_s}{\partial t} \left\{ \begin{array}{l} t = 0, T_s = T_{s,i} \\ x_1 = \infty, T_s = T_{s,i} \end{array} \right\} \quad (1)$$

$$\frac{\partial^2 T_o}{\partial x_2^2} = \frac{1}{\alpha_o} \frac{\partial T_o}{\partial t} \left\{ \begin{array}{l} t = 0, T_o = T_{o,i} \\ x_2 = \infty, T_o = T_{o,i} \end{array} \right\} \quad (2)$$

Figure 1. Schematic diagram of finger-object contact heat transfer

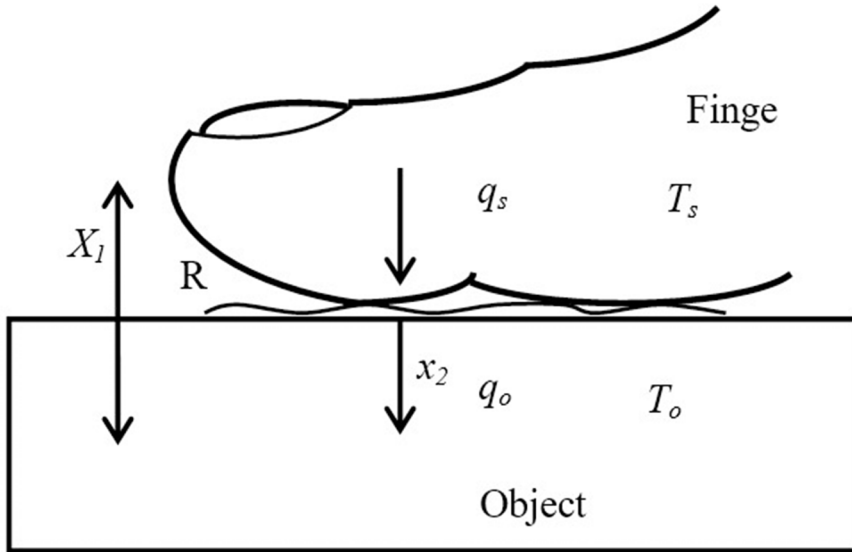

Boundary conditions on the contact surface of the finger and the object is shown as equation (3).

$$q_{s,s} = q_{o,s} = \frac{T_{s,s} - T_{o,s}}{R} \quad (3)$$

In Equations (1) to (3),  $T_s$  and  $T_j$  respectively represent the skin temperature of fingers and the temperature of objects at the contact surface.  $T_{s,i}$  and  $T_{o,i}$  respectively represent the initial temperature of finger skin and object before contact,  $q_{s,s}$  and  $q_{o,s}$  respectively represent the heat flow from the finger skin at the contact surface and the heat flow into the object,  $\alpha_s$  and  $\alpha_o$  represent the thermal diffusivity of the skin and the object, respectively, and  $x_1$  and  $x_2$  represent the distance from the contact surface,  $t$  represents the contact time of the finger and the object, and  $R$  is the thermal resistance on the contact surface. According to equations (1) to (3), the functional relationship between the skin temperature of fingers at the contact position and the contact time can be derived, that is:

$$T_s(t) = \frac{(T_{o,i} - T_{s,i})e_o}{e_o + e_s} \left\{ 1 - e^{\alpha_s A^2 t} \operatorname{erfc} \left[ A \sqrt{\alpha_s t} \right] \right\} + T_{s,i} \quad (4)$$

$$A = \frac{1}{k_s R} \left( 1 + \frac{e_s}{e_o} \right) \quad (5)$$

In equations,  $K_s$  represents the thermal conductivity of finger skin,  $e_s$  and  $e_o$  respectively represent the thermal storage coefficient of finger skin and object.

As can be seen from equations (4), if the temperature of the finger is higher than that of the contact object, the change of skin temperature on the contact surface of finger after contact with the object is decayed exponentially. On the contrary, the change in finger skin temperature is exponentially increased and eventually reaches a relatively stable temperature.

Thermal tactile perception and reproduction can be realized by changing the skin temperature of fingers on the contact surface.

### 3. THERMAL TACTILE PERCEPTION AND RECONSTRUCTION DEVICE BASED ON COMPOUND CONTROL

The thermal tactile sensing and reproducing devices reported in the current literature are mainly based on the semiconductor refrigerator, the semiconductor refrigerator can raise and lower the temperature quickly, human hands touch the surface of one end of the semiconductor refrigerator to perceive thermal tactile sensation, and PID algorithm is used to control the temperature change to achieve thermal tactile reappearance (Yang, Jones, & Kwon, 2008; Wu, Zhou, Li, Wu, & Chen, 2010; Zhou, Li, & Chen, 2010; Bai, Li, Chen, Wu, & Cai, 2011; Hirai, & Miki, 2019; Chen, Wang, & Wang, 2016; Jones, & Berris, 2003).

#### 3.1. Hardware Design of the System

In this paper, the semiconductor refrigerator is selected as temperature generating devices with maximum working current of 6A, maximum working voltage of 18V and maximum cooling capacity of 57.6 KJ. In the ambient temperature of  $23 \pm 1^\circ\text{C}$ , 1 KHZ ac test conditions, stick Pal device internal resistance value is 2.5-3.0  $\Omega$ . The internal resistance of the semiconductor refrigerator is nonlinear under different ambient temperatures and operating currents. The cooling or heating power is also non-linear with the operating current or voltage. Therefore, the compound control strategy composed of maximum proportional control, fuzzy control and PID control and PWM control scheme were used to design the experimental device for thermal tactile perception and reproduction, the temperature of the thermal tactile contact surface (the surface of the semiconductor refrigerator) can be controlled accurately and rapidly.

The design scheme and prototype of the experimental device for thermal tactile perception and reproduction are shown in Figure 2. Thermal tactile perception and repetition experiment device is mainly composed by NI company ELVISII+ experiment platform as the core, ELVIS II+ to communicate with PC through USB interface, ELVIS II + by high sensitivity linear thermistor ( $R_{25} = 3 \text{ k} \pm 1\% \Omega$ , linear positive temperature coefficient of  $12 \Omega/^\circ\text{C}$ ) testing semiconductor refrigerator surface temperature. The surface temperature of the semiconductor refrigerator is controlled by PWM output, and the start and stop of the water-cooling system is controlled by digital I/O port. Based on LabVIEW, a virtual instrument for thermal tactile perception and reproduction is designed in the computer. NI ELVIS II integrates 16-bit data acquisition card (1.25 MS/s single channel), 2 channel 16 bit analog output (2.8 MS/s biggest update rate) and 24 digital I/O port.

The driver module of the semiconductor refrigerator was controlled by PWM (Pulse-Width Modulation), which can make the semiconductor refrigerator work under the continuously adjustable voltage of 0-12v. The direction control terminal controls the operating current direction of the semiconductor cooler through the H-bridge, thereby quickly and accurately controlling the temperature of the semiconductor refrigerator. The drive module circuit of the semiconductor refrigerator is shown in Figure 3. The H bridge is composed of two P channel enhanced field effect tubes (IRF9540, 55V/110A) and two N channel enhanced field effect tubes (IFR3205, 100V/19A). The chip CD4011 integrates four NAND gate gates with two inputs to control the current direction of the H bridge through the semiconductor refrigerator. The working voltage range of CD4011 is -0.5v-18v. The function of

Figure 2. Experimental device of thermal tactile perception and reproduction

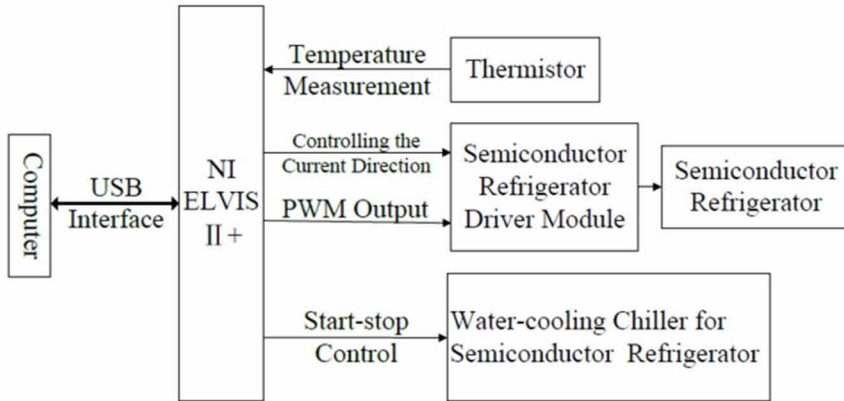

(a) Design scheme block diagram of experiment device

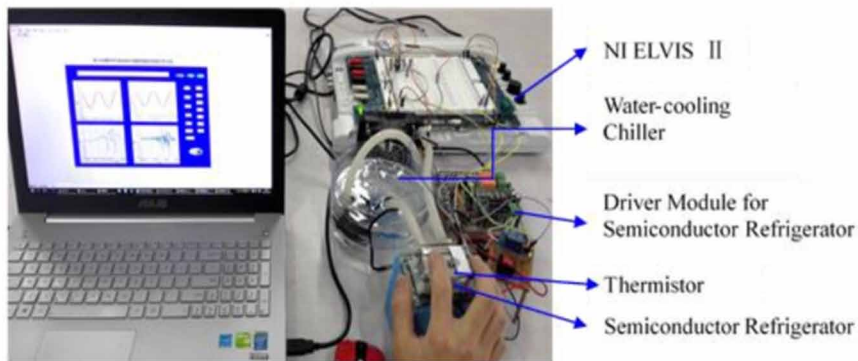

(b) Experimental equipment

the driving module circuit of the semiconductor refrigerator is shown in Table 1. By adjusting the duty cycle output of PWM, the heating/cooling power and the working surface temperature of the semiconductor refrigerator can be precisely controlled.

### 3.2. Software Design of the System

In the paper, combined with the advantages and disadvantages of fuzzy control and PID control, a composite control algorithm based on threshold switching is designed. The algorithm combines the advantages of proportional control, fuzzy control and classical PID control to make up for the pure fuzzy control system. There is no integral effect and can't eliminate the shortage of static error, which makes up for the shortcoming of the classical PID parameter can't be adaptively adjusted. The structure of the control algorithm is shown in Figure 4. Input error  $e$  is equal to the difference between the set temperature value and the actual temperature value of the thermal tactile contact surface. When  $e$  is greater than the set threshold value, the maximum proportion control can improve the response speed of the system. When the deviation  $e$  is less than the set threshold value, switch to fuzzy control and adjust the system adaptably based on fuzzy rules to improve the damping characteristics of the system and reduce overshoot in the response process. When the error  $e$  is close to the set temperature, then switch to the classical PID control, the integral function can eliminate

Figure 3. Drive circuit for semiconductor chiller

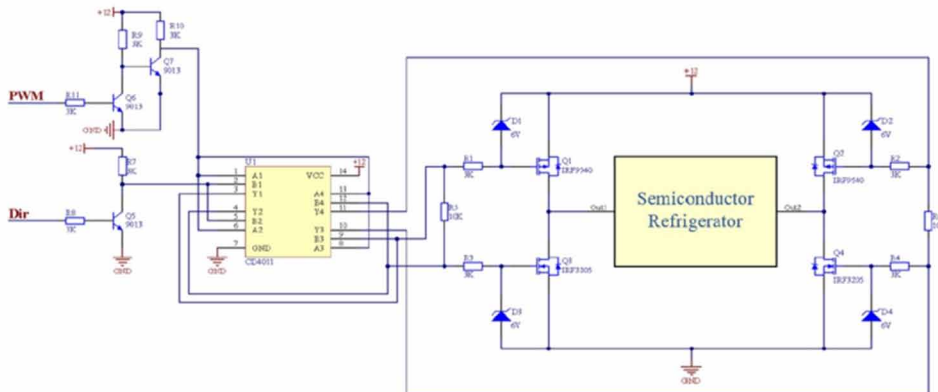

the steady-state error. This combined control algorithm based on threshold switching can make the system have fast response speed, high precision and adaptive control of anti-interference change. The compound control switching decision adopted in the thermal tactile experiment device designed in this paper is shown in equation (6) .

When  $|e| > 6^{\circ}\text{C}$ , the maximum proportional control will be executed, and the control ratio of the PWM control is 100%, and the temperature of the refrigerator is controlled to decrease or increase at full speed. When  $1 \leq |e| \leq 6^{\circ}\text{C}$ , it will be switched to the fuzzy controller and the Mamdani-type fuzzy controller is select for design. The structure is shown in Figure 5.  $K_{ec}$  is the quantization factor. By adjusting  $K_{ec}$ , the actual theoretical domain of the rate of change of error is mapped to the interval  $[-1, 1]$ .  $K_u$  is a scaling factor. By adjusting  $K_u$ , the output variable is scaled to a certain scale, and  $K_u$  is equivalent to the total magnification of the system.

In the fuzzy controller, the domain of the error  $e$  is set to  $[-6, 6]$ , and when the actual temperature error  $e$  is  $1 \leq |e| \leq 6^{\circ}\text{C}$ , the fuzzy controller plays a controlling role. By adjusting  $K_{ec}$ , the rate of change of error is mapped to the domain  $[-1, 1]$ . The domain of the output variable  $u$  is  $[-1, 1]$ . According to the actual situation of the control system, the output variable can be scaled according to a certain scale by adjusting the scaling factor  $K_u$ , and the response speed and control precision of the temperature control system can be better adjusted. Seven fuzzy subsets were selected: negative large (NB), negative medium (NM), negative small (NS), zero (ZO), positive small (PS), positive median (PM) and positive large (PB), covering the theoretical domains of variables  $e$ ,  $e_c$  and  $u$  respectively. Their membership degrees are shown in Figure 6 and Figure 7 respectively.

Table 1. Function Table for Drive Circuit

PWM	Dir	Working Current Direction of Semiconductor Refrigerator
High period	High level	Out2 to Out1
High period	Low level	Out1 to Out2
Low period	High level	No current
Low period	Low level	No current

Figure 4. Composite control algorithm based on threshold switching

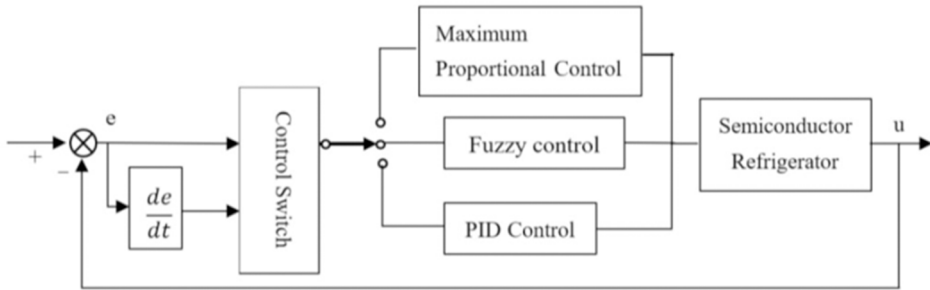

According to the actual requirements of the control system, 49 control rules are developed, as shown in Table 2. Each fuzzy rule gives an implication relation  $R_i$  ( $i = 1, 2, \dots$ ). The union of these 49 implication relations  $R_i$  constitutes the total fuzzy implication relation  $R$  of the system.

The total output of approximate reasoning is shown as equation (7) and (8).

$$R = R_1 \cup R_2 \dots \cup R_{48} \cup R_{49} = \bigcup_{i=1}^{49} R_i \quad (7)$$

$$U^* = \xrightarrow{(A^*)^T} \circ \bigcup_{j=1}^{49} R_j \quad (8)$$

Fuzzy reasoning is carried out by 49 control rules. The clear method of output is the area center method, and the output surface of the fuzzy reasoning system is shown in Figure 8.

Figure 5. Structure of the fuzzy controller

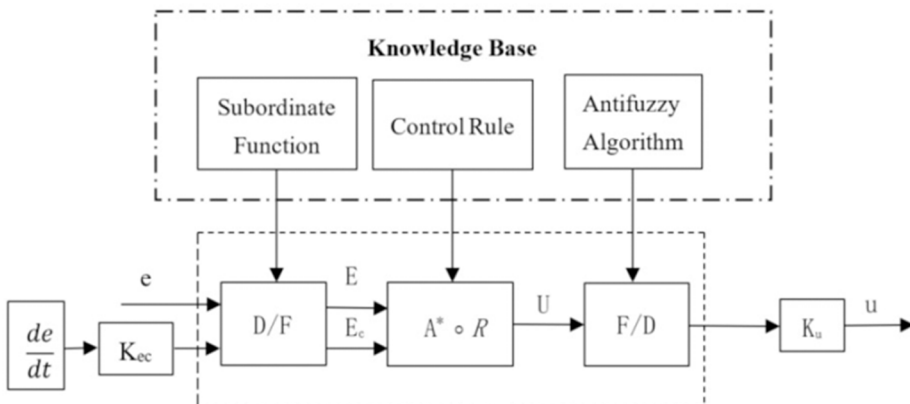

Figure 6. Fuzzy subsets distribution of the input variable

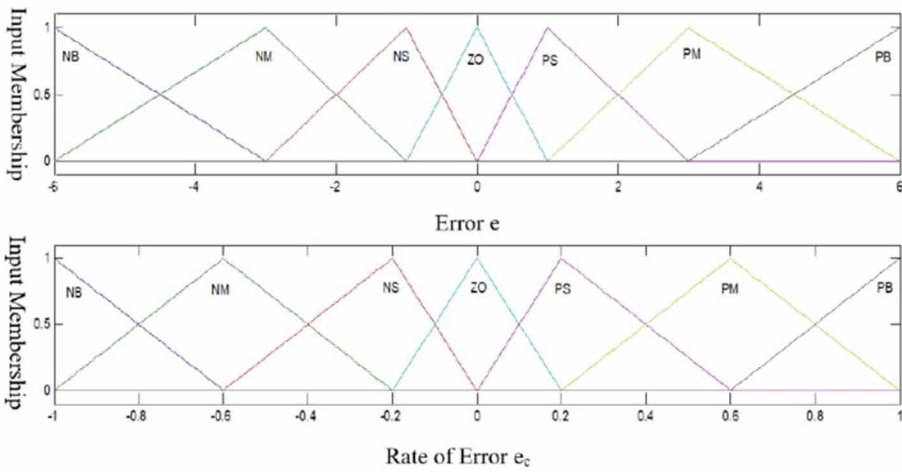
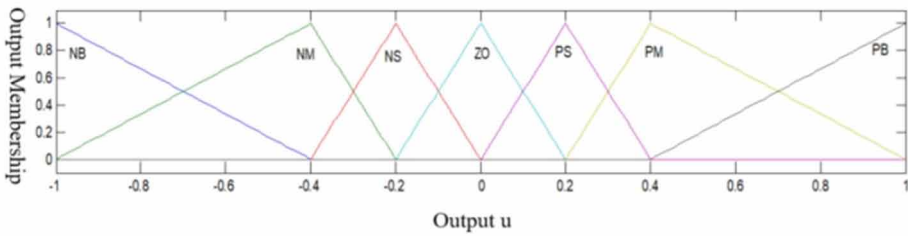

Figure 7. Fuzzy subsets distribution of the output variable



### 3.3. Experimental Results

The temperature control range of the device is from  $-10^{\circ}\text{C}$  to  $130^{\circ}\text{C}$ , the temperature resolution and accuracy were  $0.01^{\circ}\text{C}$  and  $\pm 0.1^{\circ}\text{C}$ . At  $20^{\circ}\text{C}$  and  $40^{\circ}\text{C}$  temperature control range, heating or cooling

Table 2. Fuzzy Control Rules

Error	Rate of Error Change $e_c$						
	NB	NM	NS	ZO	PS	PM	PB
	Output $u$ of Fuzzy Controller						
NB	NB	NB	NB	NB	NB	NB	NB
NM	NM	NM	NM	NM	NM	NM	NM
NS	NM	NS	ZO	ZO	ZO	NS	NM
ZO	PS	PS	ZO	ZO	ZO	NS	NS
PS	PM	PS	ZO	ZO	ZO	PS	PM
PM	PM	PM	PM	PM	PM	PM	PM
PB	PB	PB	PB	PB	PB	PB	PB



Figure 8. The output surface of the fuzzy inference system

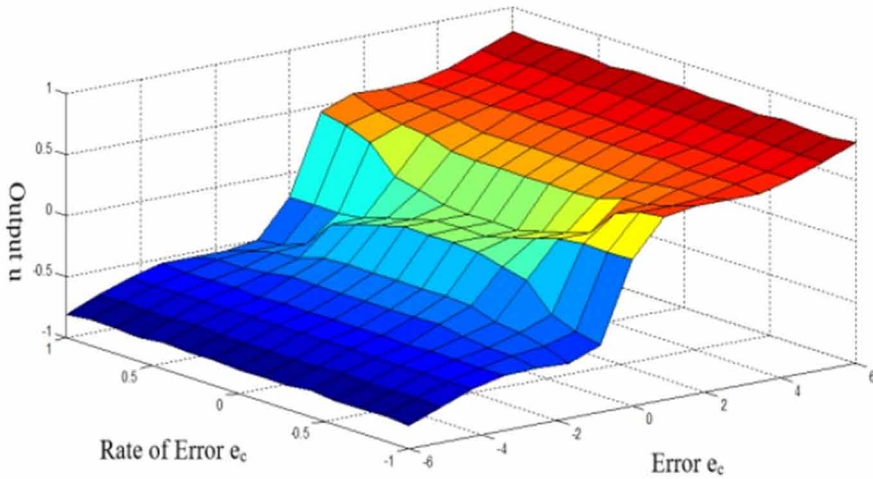

rate is greater than  $12^{\circ}\text{C/s}$ . Temperature output of any waveform can be realized by the experimental device for thermal tactile perception and reproduction. Temperature limit tests on system were carried out. As shown in Figure 9, the refrigerator temperature was raised from  $-10^{\circ}\text{C}$  to  $100^{\circ}\text{C}$  in 20 s, and was lowered from  $130^{\circ}\text{C}$  to  $0^{\circ}\text{C}$ . Figure 10. is warming waveform from  $0^{\circ}\text{C}$  to  $60^{\circ}\text{C}$  and cooling waveform from  $60^{\circ}\text{C}$  to  $0^{\circ}\text{C}$ . Figure 11. shows a sinusoidal tracking waveform with a  $1^{\circ}\text{C}$  fluctuation at  $10^{\circ}\text{C}$  of which cycle is 100 seconds, and a sinusoidal tracking waveform with a  $1^{\circ}\text{C}$  fluctuation at  $15^{\circ}\text{C}$  of which cycle is 100 seconds. It can be seen from these waveform that the temperature control system based on the composite switching algorithm of threshold switching has fast response speed, small overshoot, strong adaptability and good robustness. In the follow-up work of this paper, the device was applied to conduct thermal tactile perception characteristics experiment. The man-machine interface of the system is flexible, convenient and reliable.

There is a very nonlinear between the temperature of semiconductor refrigerator and the current or voltage flowing through it. As can be seen from the above experimental results, the composite control algorithm based on threshold switching (as shown in Figure 4) achieves a good effect in temperature

Figure 9. Limit test waveform of temperature control system

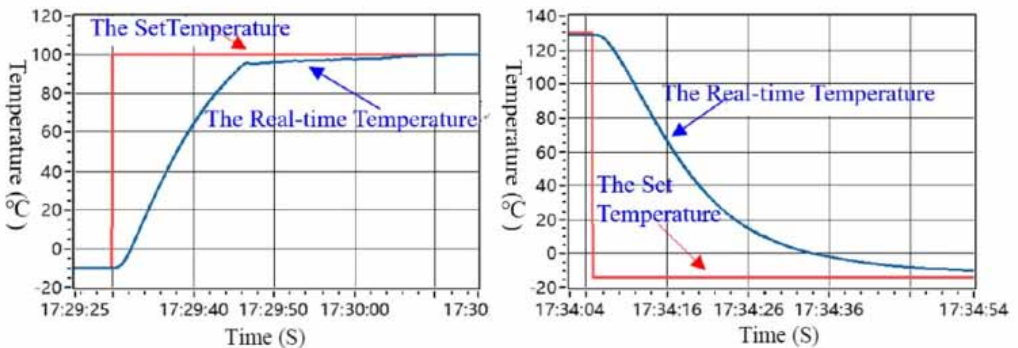
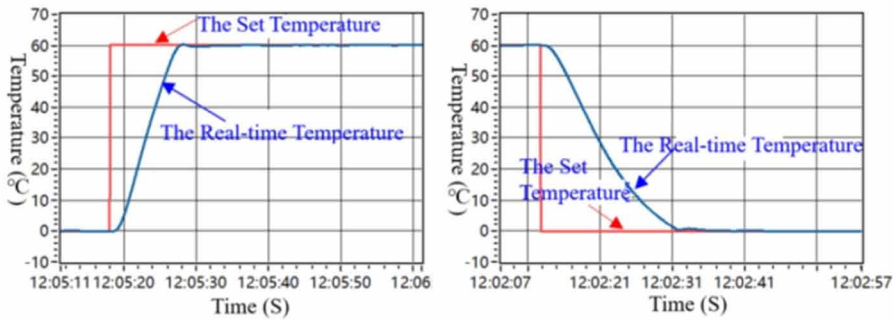

Figure 10. The warming waveform from 0°C to 60°C and cooling waveform from 60°C to 0°C



control of the semiconductor refrigerator, with fast temperature control speed and high temperature control accuracy, which is difficult to achieve with the classical PID algorithm.

#### 4. THERMAL TACTILE DIFFERENCE THRESHOLD MEASUREMENT EXPERIMENT OF FINGERS

Psychophysics is a discipline that studies the relationship between psychological quantity and physical quantity, and its research scope includes sensation, perception, emotion, behavior and attention, and so on (Zhu, 2016). Physical quantity refers to the stimulation of various senses of the body, such as force, heat, light and electricity. Psychological quantity refers to various feelings or subjective impressions, such as hot and cold, weight, comfort and discomfort, cheerful and sad, etc. In this paper, the experiment of thermal tactile difference threshold measurement was carried out, which lays a foundation for future studies on thermal tactile sensation and reproduction.

Absolute threshold and differential threshold are two concepts in psychophysics. The absolute threshold is the intensity of a physical stimulus that has 50% probability of causing sensation and 50% probability of not causing sensation. The difference threshold is that there is 50% probability of being able to detect the difference, and 50% probability of not being able to detect the difference in the intensity of other stimuli. The difference threshold is also called the minimum perceptible difference, and the difference threshold changes with the change of the original physical stimulus value (Zhu, 2016). There are three methods to measure threshold, including minimum change method, constant

Figure 11. Sine Tracking Waveform Fluctuating Up And Down 1°C From 10°C Or 15°C

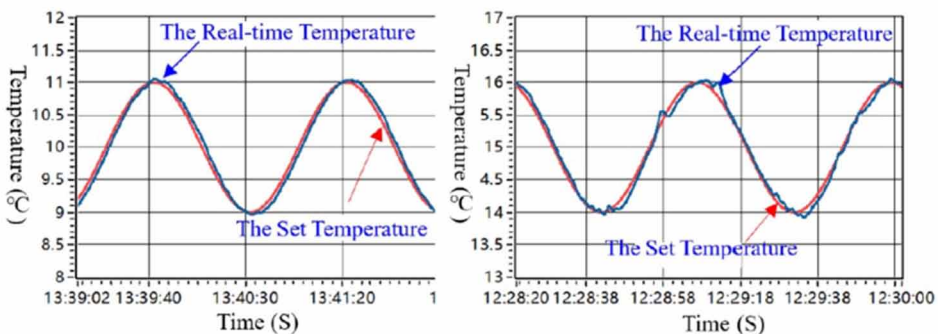

stimulation method and average error method. The measurement experiments of the thermal tactile temperature difference threshold of fingers were carried out respectively on standard stimulus of 15 °C, 33 °C and 47 °C.

#### 4.1. Experimental Objective, Subjects and Equipment

The experimental objective is to measure the thermal tactile temperature difference threshold of fingers.

25 college students (15 boys and 10 girls) were randomly selected from the college students who volunteered to take part in the test. All of them were healthy and had no thermal tactile dysfunction. Their emotions were calm and normal during the experiment.

Experimental equipment for thermal tactile perception and reproduction is as shown in Figure 2(b).

#### 4.2. Experimental Procedure

In order to ensure the effectiveness of the experiment, the following experimental procedures should be followed.

- (1) Indoor temperature is set to  $26\pm 1^{\circ}\text{C}$ .
- (2) before the experiment, subjects should wash their hands with hand sanitizer.
- (3) In each experiment, before the subjects touched the contact surface of the thermal tactile apparatus, the temperature of the index finger was measured by the infrared temperature detector and the temperature of the index finger should be controlled at  $30\pm 1^{\circ}\text{C}$  before each experiment. The pressure of touching the contact surface of the experimental device is basically the same in each experiment.
- (4) In order to prevent the adaptability of finger thermal tactile perception and avoid tactile fatigue, the time interval of two consecutive experiments is 3-5 minutes.

#### 4.3. Experimental Methods

According to the experimental purpose, the experimental method is as follows.

- (1) 15°C was elected as the standard stimulus. 9°C, 11°C, 13°C, 15°C, 17°C, 19°C and 21°C were selected as comparison stimulus. standard and to stimulate the stimulation of pair of stimulation. The combination of standard stimulus and comparative stimulus is a pair of stimuli.
- (2) Each pair of stimuli was presented randomly, and participants were asked to compare the comparison stimulus with the standard stimulus. Only subjects were allowed to answer “high” or “low”. If the subjects felt that the stimulus temperature was higher than the standard stimulus temperature, they would answer “high”, otherwise, they would answer “low”.
- (3) For each subject, each stimulus was compared with the standard stimulus for 4 times (100 times in total), and the standard stimulus and the comparison stimulus were presented successively, in which 2 times of the standard stimulus were before the comparison stimulus and 2 times of the standard stimulus were after the comparison stimulus;
- (4) Through the statistics and analysis of experiment data, the standard stimulus for 15 °C temperature difference threshold was calculated.
- (5) When 33°C was selected as the standard stimulus, 27°C, 29°C, 31°C, 33°C, 35°C, 37°C, and 39°C were selected as comparison stimulus. By repeating steps (2) and (3), the standard stimulus for 33°C temperature difference threshold was calculated.
- (6) When 47°C was selected as the standard stimulus, 41°C, 43°C, 45°C, 47°C, 49°C, 51°C, and 53°C were selected as comparison stimulus. By repeating steps (2) and (3), the standard stimulus for 47°C temperature difference threshold was calculated.

Table 3. Experimental Data of Temperature Difference Threshold of Finger Thermal Tactile

Experiment 1	comparison stimulus(°C)	9	11	13		15		17	19	21
		The proportion above the standard stimulus 15 °C	4%	14%	43%		53%		63%	72%
Experiment 2	Comparison stimulus(°C)	27	29	31		33		35	37	39
		The proportion above the standard stimulus33°C	1%	7%	16%		49%		71%	92%
Experiment3	Comparison Stimulus(°C)	41	43	45		47		49	51	53
		The proportion above the standard stimulus 47°C	7%	19%	47%		56%		67%	76%

#### 4.4. Experimental Data and Results

When standard stimulus were 47 °C, 15 °C, 33 °C and 47°C, the experiment data of temperature difference threshold measurement are shown as in Table 3. The method for calculating the temperature difference threshold is 75% difference threshold method.

To calculate the temperature difference threshold, 75% difference threshold method is adopted as follows:

- (1) Based on the linear interpolation method, the comparison stimulus of 75% times of feeling higher than the standard stimulus was calculated as the upper limit  $\delta_1$  of the equal area, which is between the comparison stimulus of 50% times of feeling higher than the standard stimulus and the comparison stimulus of 100% times of feeling higher than the standard stimulus.
- (2) Take 25% of the sensation that is higher than the standard stimuli as the lower limit  $\delta_2$  of the equal zone, which is at the midpoint between 0 and 50% of the stimuli above the standard stimuli.
- (3) Calculate the temperature difference threshold  $\delta$ ,  $\delta = (\delta_1 - \delta_2) / 2$ .

According to the above method, the temperature difference threshold calculation results is as shown in Table 4. When the standard stimuluses are 15°C, 33°C and 47°C respectively, the temperature difference thresholds are 3.78°C, 1.51°C and 3.67°C respectively, which shows that the finger temperature difference threshold is small and high temperature resolution when the standard stimulus temperature close to normal skin temperature 33°C. When the temperature of the standard stimulus is relatively low or high temperature (15 °C and 47 °C), temperature difference threshold of a finger will increase, and the temperature resolution of a finger will be lower. It can also be seen from the experimental data that when the difference between the comparison stimulus temperature and the standard stimulus temperature is greater, the thermal tactile sensation of fingers will be stronger, and the temperature recognition rate will be higher. Under the stimulation of different temperatures, Weber ratio of thermal haptics is not constant[20], the thermal haptic stimulus of 15°C corresponds to the largest value of K (K=0.252), the thermal haptic stimulus of 47°C corresponds to a smaller value of K. (K = 0.078), and the thermal tactile stimulus of 33°C corresponds to the smallest K value (K = 0.046).

#### 5. EMOTION RECOGNITION EXPERIMENTS BASED ON THERMAL TACTILE SENSATION

Embodied cognition science is a new research field in psychology and a new direction in cognitive psychology. Embodied cognition theories mainly refer to the strong connection between physical

Table 4. Calculation Results of Temperature Differential Threshold

The experimental project	Upper limit, $\delta_1$	Lower limit, $\delta_2$	Temperature difference threshold $\delta$	Weber ratio, K
Temperature difference threshold measurement for standard stimulus 15 °C	19.32 °C	11.76 °C	3.78 °C	0.252
Temperature difference threshold measurement for standard stimulus 33 °C	34.57 °C	31.55 °C	1.51 °C	0.046
Temperature difference threshold measurement for standard stimulus 47 °C	50.78 °C	43.43 °C	3.67 °C	0.078

experience and mental state (Landau, Meier, & Keefer, 2010). Physical experiences activate psychological feelings, and vice versa.

In recent years, with the rise of embodied cognition science, the relationship between temperature and social cognition has been paid more attention to. A large number of studies have shown that changes in environmental temperature and exposure to cold or hot objects affect social behavior, especially those related to emotions. For example, imagining of social rejection would lead to an underestimate of room temperature, people tend to overestimate the room temperature under the stimulus of anger, and the experience of physical warmth can promote the generation of psychological warmth (such as closeness, trust, etc.). Therefore, physical temperature can serve as a situational clue to guide people's interpersonal judgment and behavior, so that temperature can make a psychological substitution with social emotion.

At present, the research results of cognitive neuroscience show that the processing of physical temperature and social emotion information activates the same brain regions, which are shared on the same insula; that insula is a shared neural matrix that regulates the mapping of physical temperature to social emotion; and that, since the intensity of temperature perception induced by warm and cold stimuli is significantly correlated with the activities in the insula, this brain region is also thought to be involved in processing emotional information (Craig, Chen, & Bandy, 2007; Sung, Yoo, & Yoon, 2007; Eisenberger, Lieberman, & Williams, 2003).

In this section, the relationship between thermal tactile sensation and emotion based on temperature cues will be studied through experiments, including the mapping experiment of emotion and temperature, and the emotion recognition experiment induced by thermal tactile sensation.

## 5.1. The Mapping Experiment of Emotion and Temperature

### 5.1.1. Experimental Objective, Subjects, Equipment and Procedure

Experiment objective is to study the mapping relationship between psychological emotion and physical temperature, based on the emotion priming paradigm of psychology, using facial expression pictures as priming stimuli and using temperatures as target stimuli.

20 college students (10 boys and 10 girls) were randomly selected from the college students who volunteered to take part in the test. All of them were healthy and had no thermal tactile dysfunction. Their emotions were calm and normal during the experiment.

The experimental equipment for thermal tactile perception and reproduction and the experimental procedure are the same as section 4 of this paper.

### 5.1.2. Experimental Methods

According to the experimental purpose, the experimental method is as follows.

Table 5. The Mapping Relationship Between Psychological Emotion and Physical Temperature

Emotional categories	The temperature range corresponding to emotion	The average temperature corresponding to emotion
Calm	25-35 °C	30.5 °C
Happy	36-45 °C	40.9 °C
Sad	14-21 °C	14.7 °C
Angry	47-52 °C	49.55 °C

- (1) First of all, using the Chinese face emotion picture system produced by Yuejia Luo (Gong, Huang, Wang, & Luo, 2011), 16 pictures of representative and significantly different facial expressions were selected by 4 graduate students, including 4 calm, 4 happy, 4 sad and 4 angry pictures. Moreover, according to the emotional categories of faces, the pictures were divided into four groups and each group pictures included two pictures of male and two pictures of female, as shown in Figure 12.
- (2) Each subject's emotions (calm, happy, sad, and angry) were aroused through pictures of facial expressions used as priming stimulus. After the corresponding emotion were stable for a period of time, the index finger of the right hand contacted the thermal tactile perception surface of the experimental device. The subjects independently adjusted the temperature of the tactile perception surface, found the temperature range consistent with the corresponding emotion, and filled in the representative temperature used as target stimulus corresponding to the emotion on the test form.

### 5.1.3. Experimental Results

The results of the emotion and temperature mapping experiment are shown in Figure 12. The physical temperature corresponding to calm emotion is 25 to 35°C, and the average temperature is 30.5°C. The physical temperature corresponding to happy emotion is 36 to 45°C, and the average temperature is 40.9°C. The physical temperature corresponding to sadness emotion is 12 to 18°C, and the average temperature is 14.7°C. The physical temperature corresponding to anger emotion is 47 °C to 52°C and the average temperature is 49.55°C. The experimental results are shown in Table 5.

## 5.2. The Emotion Recognition Experiment Induced by Thermal Tactile Sensation

### 5.2.1. Experimental Objective, Subjects, Equipment and Procedure

Sad expressions and angry expressions are indistinguishable from each other in certain features, such as the unpleasant expression of facial expression and the frown state. Therefore, when using intuition to quickly identify the type of expression, the recognition results are often wrong. Based on the Stroop experimental paradigm of psychology [216], the experiment objective is to study the role of thermal tactile perception in emotion recognition, using temperature as priming stimulus and using sad and angry facial pictures as the target stimulus.

The subjects and the experimental equipment and the experimental procedure are the same as section 5.1 of this paper.

### 5.2.2. Experimental Methods

According to the experimental purpose, the experimental method is as follows.

- (1) First of all, using the Chinese face emotion picture system produced by Yuejia Luo (Gong, Huang, Wang, & Luo, 2011), four graduate students selected 4 sad and 4 angry facial pictures with no

Figure 12. Pictures of calm, happy, sad and angry facial expressions



(a) Calm face pictures (2 men and 2 women)



(b) Happy face pictures (2 men and 2 women)



(c) Sad pictures (2 men and 2 women)



(d) Angry face pictures (2 men and 2 women)

Figure 13. Sad and angry facial emotion pictures used in the experiment



significant difference (4 male and 4 female), as shown in Figure 13. Before the experiment, the subjects were told in advance that there were only two emotional types of sadness and anger in the pictures presented to them, and they were asked to make a choice. Moreover, the emotional types of the pictures should be determined as quickly as possible according to their intuition in 10 seconds.

- (2) The experiment was divided into three batches: recognizing image emotion without thermal tactile excitation, recognizing image emotion by thermal tactile excitation at 15°C, and recognizing image emotion by thermal tactile excitation at 50°C.
- (3) Each batch experiment operation is as follows. The experimenter randomly distributed sad and angry face images to the 20 subjects, and asked the subjects to judge the image emotion type. The subjects orally reported the judgment results to the experimenter. The subject's response time to identify the emotional type of each picture was recorded by a stopwatch.
- (4) During the experiment of image emotion recognition under thermal tactile excitation at 15°C or 50°C, the subjects were asked to touch the thermal tactile perception surface of the experimental device with their index fingers. At the temperature of 15°C or 50°C, the emotional effect of the subjects was activated, and then the subjects were asked to identify the emotion type of the pictures. As soon as the subjects saw the picture, the experimenter started stopwatch. The experimenter stopped stopwatch when the subjects orally reported the emotional type of the picture.

### 5.2.3. Experimental Results

Through the above experiments, the experimental results are as follows. The average response time and error rate of facial emotion recognition are shown in Table 6. There is a significant interaction between thermal tactile excitation and picture emotion type. For the sad emotion, under the “cold”



Table 6. The Average Response Time and Error Rate of Facial Emotion Recognition Based on Thermal Tactile Stimulation

Type of thermal tactile stimulus loaded on the index finger	Sad facial pictures		Angry facial pictures	
	Response time	Error rate	Response time	Error rate
Without thermal stimulation	4.19 s	6.875%	3.98 s	5.0%
Under thermal tactile stimulation at 15°C	3.67 s	4.375%	4.26 s	9.375%
Under thermal tactile stimulation at 50°C	4.52 s	10.625%	2.49 s	3.125%

thermal tactile excitation with a temperature of 15°C, the reaction time is significantly less than that under the “hot” thermal tactile excitation with a temperature of 50°C, and the recognition error rate is significantly reduced to 4.375%. For the angry emotion, under the “hot” thermal tactile excitation with a temperature of 50°C, the reaction time is significantly less than that under the “cold” thermal tactile excitation with a temperature of 15°C, and the recognition error rate is significantly reduced to 3.125%.

The experimental results shown in Table 6 also further verify that, in the emotional Stroop experimental paradigm, when the valence of the priming stimulus is consistent with that of the target stimulus, the recognition accuracy of the target stimulus is significantly higher than that of the incongruent stimulus, and the response time is relatively shorter. Individuals are more sensitive to target stimulus that are consistent with priming stimuli in emotional potency, mainly in processing speed and attention selection.

## 6. CONCLUSION AND FUTURE WORK

In this paper, the thermal tactile perception and reproduction experiment device was designed by virtual instrument technology and a composite control algorithm. The experimental device has excellent performance, good reliability, flexible human-computer interaction, faster and more accurate temperature control, and can meet the experimental requirements of thermal tactile perception and reproduction. Based on the experimental device, the temperature difference threshold of thermal tactile of the finger was measured according to the psychophysical experimental specifications, and the relationship between thermal tactile sensation and emotion based on temperature cues has been explored, which provides experimental basis and technical support for the future research, such as force tactile reproduction based on thermal tactile auxiliary, thermal tactile navigation, perceiving music by thermal tactile, and so on.

## ACKNOWLEDGMENT

This research is funded by Research Foundation of Chongqing City Program of Basic Research and Frontier Technology (Grant No. cstc2020jcyj-msxmX0452, cstc2018jcyjA1838), Open Research Foundation of Innovation Platform of Fujian University of Technology (Grant No. KF-X18020), National Natural Science Foundation of China (Grant No. 61873043).

## REFERENCES

- Bai, J., Li, J., Chen, C., Wu, J., & Cai, F. (2011). Thermal tactile display device and material recognition experiment in virtual environment. *Journal of Southwest University (Natural Science Edition)*, 41(6), 1197–1201.
- Chen, C., Wang, Y., & Wang, W. (2016). Research on thermal tactile reproducing device based on compound partial module. *Journal of Instrumentation: An IOP and SISSA Journal*, 37(11), 2521–2527.
- Choi, S., & Kuchenbecker, K. J. (2013). Vibrotactile Display: Perception, Technology, and Applications. *Proceedings of the IEEE*, 101(9), 2093–2104. doi:10.1109/JPROC.2012.2221071
- Craig, A. D., Chen, K., Bandy, D., & Reiman, E. M. (2000). Thermosensory activation of insular cortex. *Nature Neuroscience*, 3(2), 184–190. doi:10.1038/72131 PMID:10649575
- Eisenberger, N. I., Lieberman, M. D., & Williams, K. D. (2003). Does rejection hurt? An FMRI study of social exclusion. *Science*, 302(5643), 290–292. doi:10.1126/science.1089134 PMID:14551436
- Giordano, M., & Wanderley, M. M. (2013). Perceptual and Technological Issues in the Design of Vibrotactile-Augmented Interfaces for Music Technology and Media. In *Haptic and Audio Interaction Design*. Springer.
- Gong, X., Huang, Y., Wang, Y., & Luo, Y. (2011). Revision of the Chinese facial affective Picture system. *Chinese Mental Health Journal*, 25(1), 40–46.
- Hirai, S., & Miki, N. (2019). A Thermal Tactile Sensation Display with Controllable Thermal Conductivity. *Micromachines*, 10(359), 1–9. doi:10.3390/mi10060359 PMID:31146492
- HO, H., & Jones, L. A. (2008). Modeling the thermal responses of the skin surface during hand-object interactions. *Journal of Biomechanical Engineering*, 130(2), 021005-1–8. PMID:18412492
- Hwang, I., Lee, H., & Choi, S. (2013). Real-time dual-band haptic music player for mobile devices. *IEEE Transactions on Haptics*, 6(3), 340–351. doi:10.1109/TOH.2013.7 PMID:24808330
- Jianxin Li works as a professor at Fujian University of Technology, Fuzhou, China. He is currently working on signal processing and human-computer interaction technology.
- Jones, L. A., & Berris, M. (2003). Material discrimination and thermal perception. *Proceedings of the 11th International Symposium on Haptic Interfaces for Virtual Environment and Teleoperator Systems*, 171-178. doi:10.1109/HAPTIC.2003.1191267
- Karam, M. M., Russo, F. A., & Fels, D. I. (2009). Designing the Model Human Cochlea: An Ambient Crossmodal Audio-Tactile Display. *IEEE Transactions on Haptics*, 2(3), 160–169. doi:10.1109/TOH.2009.32 PMID:27788080
- Landau, M. J., Meier, B. P., & Keefer, L. A. (2010). A metaphor-enriched social cognition. *Psychological Bulletin*, 136(6), 1045–1067. doi:10.1037/a0020970 PMID:20822208
- Lederman, S. J., & Jones, L. A. (2011). Tactile and Haptic Illusions. *IEEE Transactions on Haptics*, 4(4), 273–294. doi:10.1109/TOH.2011.2 PMID:26963655
- Maclean, K., & Hayward, V. (2008). Do It Yourself Haptics, Part II: Interaction Design. *IEEE Robotics & Automation Magazine*, 15(1), 104–119. doi:10.1109/M-RA.2007.914919
- Marshall, M. T. (2008). *Physical interface design for digital musical instruments*. McGill University.
- Shockley, K., Carello, C., & Turvey, M. T. (2004). Metamers in the haptic perception of heaviness and moveableness. *Perception & Psychophysics*, 66(5), 731–742. doi:10.3758/BF03194968 PMID:15495899
- Sung, E. J., Yoo, S. S., Yoon, H. W., Oh, S.-S., Han, Y., & Park, H. W. (2007). Brain activation related to affective dimension during thermal stimulation in humans: A functional magnetic resonance imaging study. *The International Journal of Neuroscience*, 117(7), 1011–1027. doi:10.1080/00207450600934432 PMID:17613111
- Wu, J., Zhou, L., Li, J., Wu, J., & Chen, C. (2010). Experimental study on temperature tactile recognition of surface thermal properties of objects. *Journal of Southwest University (Natural Science Edition)*, 40(6), 1313–1317.
- Xue Zhang is a graduate student of Chongqing University of Science and Technology. He is currently working on Cognitive Computing and Machine learning.

- Yang, G., Jones, L., & Kwon, D. (2008). Use of simulated thermal cues for material discrimination and identification with a multi-fingered display. *Presence (Cambridge, Mass.)*, 17(1), 29–42. doi:10.1162/pres.17.1.29
- Yang, G., Kwon, D., & Jones, L. A. (2009). Spatial acuity and summation on the hand: The role of thermal cues in material discrimination. *Perception & Psychophysics*, 71(1), 156–163. doi:10.3758/APP.71.1.156 PMID:19304605
- Yao, L., Shi, Y., Chi, H., & Ji, X., & Ying, F. (2010). Music-touch Shoes: Vibrotactile Interface for Hearing Impaired Dancers. *Proceedings of the fourth international conference on Tangible, embedded, and embodied interaction*, 275-276. doi:10.1145/1709886.1709944
- Yu, Y., & A, Song., Chen, D., & Zhang, G. (2017). Fingertip Force tactile reproduction system for touch screen image perception. *Journal of Instrumentation: An IOP and SISSA Journal*, 38(6), 1523–1530.
- Zhou, L., Li, J., & Chen, C. (2010). Temperature tactile surface morphology recognition. *Journal of Southwest University (Natural Science Edition)*, 40(S1), 343–347.
- Zhu, Y. (2016). *Experimental psychology* (4th ed.). Peking University Press.

*Junjie Bai works as an associate professor at Chongqing University of Science and Technology, china. He holds a Master degree in control theory and engineering from Wuhan University of Science and Technology in Wuhan, China, and a PhD in Instrument Science and Technology from Southeast University, Nanjing, China. He is currently working on Sensing Technology, Pattern Recognition, Cognitive Computing, and Machine learning. He is one of the corresponding authors of this paper.*

*Jun Peng received a PhD in Computer Software and Theory from Chongqing University in 2003, an MA in computer system architecture from Chongqing University in 2000, and a BSc in Applied Mathematics from the Northeast University in 1992. From 1992 to present he works at Chongqing University of Science and Technology, where he is currently a Professor and Dean in School of Electrical and Information Engineering. He was a visiting scholar in the Laboratory of Cryptography and Information Security at Tsukuba University, Japan in 2004, and Department of Computer Science at California State University, Sacramento in 2007, respectively. He has authored or coauthored over 70 peer reviewed journal or conference papers. He has served as the program committee member or session co-chair for over 10 international conferences such as SEKE'08, SEKE'10, ICCI'09-10, ICCI\*CC'11-17, ICTAI'10-13. His current research interests are on cryptography, chaos and network security, image processing.*

*Zuojin Li received his Ph.D. from the Chongqing University in 2010. He worked as a Post Doctor at computing department of UNITEC, New Zealand. He is now an professor at the College of Electrical and Information Engineering, Chongqing University of Science and Technology in China. His research interests cover automation control systems, image processing, pattern recognition, intelligence traffic system, etc. He is the author of about 60 journal/conference papers, and the co-inventor of over 10 patents. He is one of the corresponding authors of this paper.*

*Dedong Tang received the B.S. degree in Petroleum Mine field Mechanism from Daqing Petroleum Institute, Daqing, China, 1995; received the M.S. degree in Measuring & Testing Techniques and Instrument from Sichuan University, Chengdu, China, 1998; and received the Ph.D. degrees in Instrument Science and Technology from Chongqing University, Chongqing, China, 2007. He is currently a Professor with the College of Electrical Engineering, Chongqing University of Science and Technology, Chongqing, China. His research interests include industrial process modeling, smart sensor and testing techniques.*

*Kan Luo works as an associate professor at Fuzhou University of Technology, China. He holds a PhD in Instrument Science and Technology from Southeast University, Nanjing, China. He is currently working on signal processing and human-computer interaction technology.*